

DME 5000: distance measurement in millisecond cycles

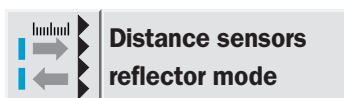

system functions; a device display with all important information available at a glance; and a particularly user-friendly mounting and alignment concept are the most important advantages of the new DME 5000 laser distance measurement system. The compact device is available in three versions that have been specially optimised for automatic small part stock, for pallets in high-bay warehouses or cranes.

The DME 5000's ambient temperature range has been designed for +55 °C to -10 °C. A variant with internal heating achieves +55 °C to -40 °C. Thus the distance measurement device is also suitable for use in deepfreeze storage systems. Warehouse type-specific versions for positioning processes at maximum speeds. Two warehouse types of differing sizes predominate: automatic small part stock for containers of varying dimensions, and structurally larger high-bay warehouses for Euro and, sometimes, system-specific pallets. The new DME 5000 is suitable for approach speeds of up to 10 m/s and takes the differing requirements of the two types of warehouses into account with its two range-optimised versions for 70 m and 150 m.



Distance measurement systems such as the DME 5000 are used in automated storage technology for detecting the position of storage and retrieval devices. In order to do this, the sensor moves with the vehicle and constantly measures the time-of-flight of an emitted light impulse to the end of the shelf aisle and back. The electronics unit determines the position of the storage and retrieval unit from this time and passes it on to the vehicle control system.

Highly dynamic and accurate measurement; multi-functional switching outputs and inputs for stand-by, preset and other

SICK

Measurement range
0.15 ... 70 m

Distance measuring device

- Short positioning processes: very fast measuring time
- High degree of system availability: highest accuracy and reproducibility
- Convenient operation startup: illuminated LCD display with diagnosis information
- Easy assembly and alignment concept: alignment bracket with spring/visible red light



Dimensional drawing

All types

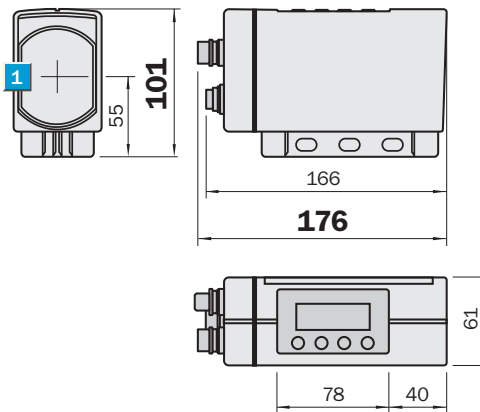

Back sight

DME5000-111	DME5000-112	DME5000-114	DME5000-115
DME5000-113			

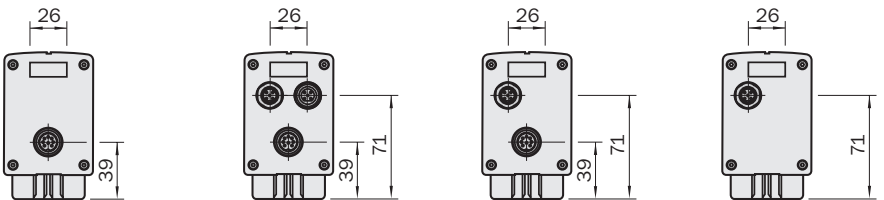

Adjustments possible

All types

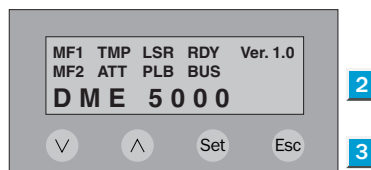

- 1 Centre of optical axis
- 2 LC display
- 3 Entry range

Connection type

DME5000-111	DME5000-112	DME5000-114	DME5000-115
DME5000-113			

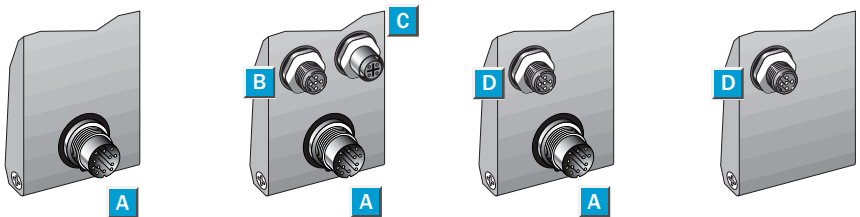

Connections

8-pin, M16	5-pin, M12 Bus in	5-pin, M12 Bus out	5-pin, M12 Bus in
------------	----------------------	-----------------------	----------------------

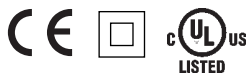
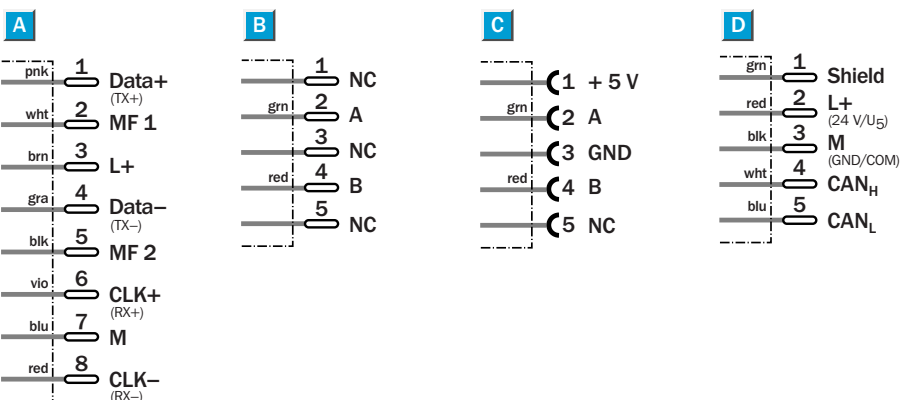

Accessories

- Connectors
- Mounting systems

Technical Data		DME5000-	111	112	113	114	115	121	122	123	124
Measurement range ¹⁾	0.15 ... 70 m										
Accuracy	±2 mm										
Reproducibility ²⁾	0.5 mm										
Light spot diameter	max. 130 mm at 70 m										
Resolution (adjustable)	0.05 ... 5 mm										
Light source ³⁾ , light type	Laser diode, red light										
Laser category	2 (IEC 60825-1/C.D.R.H.)										
Supply voltage V_S ⁴⁾	18 ... 30 V DC										
Residual ripple ⁵⁾	5 V _{pp}										
Current consumption	< 250 mA at 24 V DC										
	with heating < 1000 mA										
Switching outputs MF1, MF2	B (push/pull)										
Output (MF1/MF2)	HIGH: $U_V < 3$ V; LOW < 2 V										
Input (MF1) ⁶⁾	HIGH: > 12 V; LOW < 3 V										
Output current I_A max. ⁷⁾	100 mA (short-circuit/overload protected)										
Connection type	Plug										
VDE protection class ⁸⁾	□										
Enclosure rating	IP 65										
Ambient temperature	Operation -10 °C ... +55 °C										
	with heating Operation -40 °C ... +55 °C										
	Storage -25 °C ... +75 °C										
Weight	approx. 1650 g										
Interfaces	SSI										
	Profibus 12 MBd										
	RS 422										
	DeviceNet 500 KBd										
Effect of air pressure	0.3 ppm/hPa										
Effect of air temperature	1 ppm/K										
Temperature drift	typ. 0.1 mm/K										
Measurement value output	1 ms										
	2 ms										
Initialisation period	500 ms										
Max. running speed	10 m/s										
EMV	EN 61000-6-2, EN 55011: class B										
Mechanical load	Shock: EN 600 68-2-27/-2-29										
	Sine: EN 600 68-2-6										
	Noise: EN 600 68-2-64										

¹⁾ On reflective tape "Diamond Grade"
²⁾ Statistical error 1 σ , environmental conditions constant, minimal warm-up time: 10 min.

³⁾ Average service life 50,000 h at $T_A = +25$ °C
⁴⁾ Limit values

⁵⁾ May not exceed or fall short of V_S tolerances
⁶⁾ not reverse-polarity protected

⁷⁾ Max. 100 nF/20 mH
⁸⁾ Reference voltage 32 V DC

Order information	
Type	Part no.
DME5000-111	1 022 949
DME5000-112	1 023 668
DME5000-113	1 025 048
DME5000-114	1 025 832
DME5000-115	1 025 833
DME5000-121	1 024 083
DME5000-122	1 024 084
DME5000-123	1 025 249
DME5000-124	1 025 836

Measurement range
0.15 ... 150 m

Distance measuring device

- Short positioning processes: very fast measuring time
- High degree of system availability: highest accuracy and reproducibility
- Convenient operation startup: illuminated LCD display with diagnosis information
- Easy assembly and alignment concept: alignment bracket with spring/visible red light



Dimensional drawing

All types

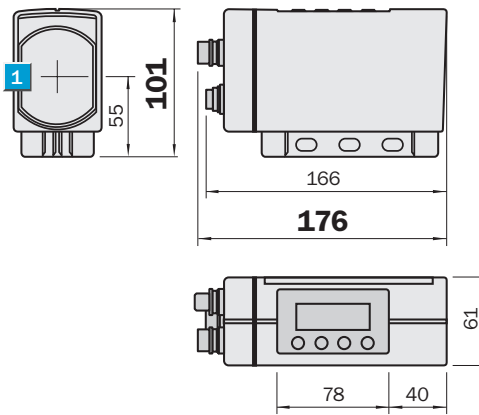

Back sight

DME5000-211	DME5000-212	DME5000-214	DME5000-215
DME5000-213			

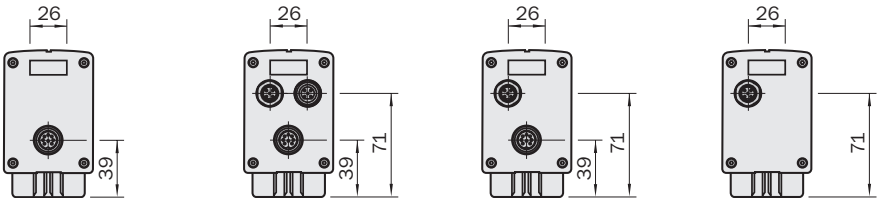

Adjustments possible

All types

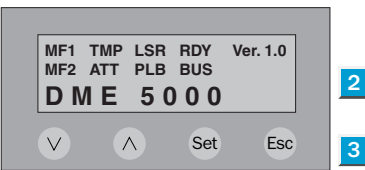

- 1 Centre of optical axis
- 2 LC display
- 3 Entry range

Connection type

DME5000-211	DME5000-212	DME5000-214	DME5000-215
DME5000-213			

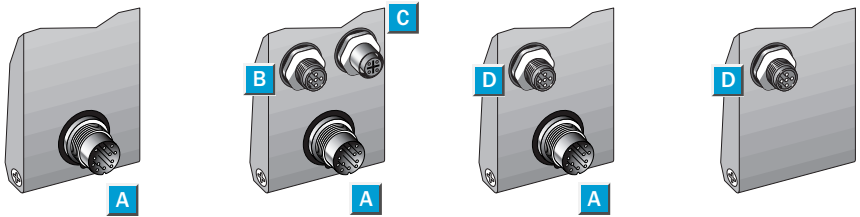

Connections

8-pin, M16	5-pin, M12 Bus in	5-pin, M12 Bus out	5-pin, M12 Bus in
------------	----------------------	-----------------------	----------------------

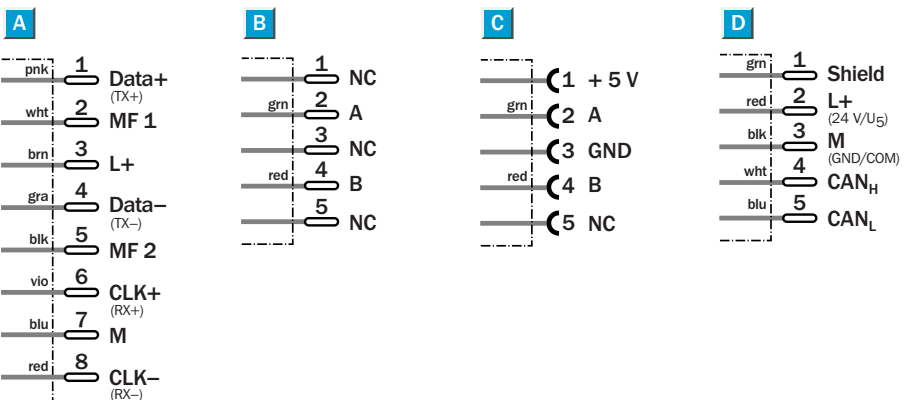

SSI **PROFI**
BUS

RS 422 **DeviceNet**

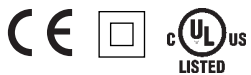

Accessories

- Connectors
- Mounting systems

Technical Data		DME5000-	211	212	213	214	215	221	222	223	224
Measurement range ¹⁾	0.15 ... 150 m										
Accuracy	±3 mm										
Reproducibility ²⁾	1 mm										
Light spot diameter	max. 270 mm at 150 m										
Resolution (adjustable)	0.05 ... 5 mm										
Light source ³⁾ , light type	Laser diode, red light										
Laser category	2 (IEC 60825-1/C.D.R.H.)										
Supply voltage V_S ⁴⁾	18 ... 30 V DC										
Residual ripple ⁵⁾	5 V _{pp}										
Current consumption	< 250 mA at 24 V DC										
	with heating < 1000 mA										
Switching outputs MF1, MF2	B (push/pull)										
Output (MF1/MF2)	HIGH: $U_V < 3$ V; LOW < 2 V										
Input (MF1) ⁶⁾	HIGH: > 12 V; LOW < 3 V										
Output current I_A max. ⁷⁾	100 mA (short-circuit/overload protected)										
Connection type	Plug										
VDE protection class ⁸⁾	□										
Enclosure rating	IP 65										
Ambient temperature	Operation -10 °C ... +55 °C										
	with heating Operation -40 °C ... +55 °C										
	Storage -25 °C ... +75 °C										
Weight	approx. 1650 g										
Interfaces	SSI										
	Profibus 12 MBd										
	RS 422										
	DeviceNet 500 Kbd										
Effect of air pressure	0.3 ppm/hPa										
Effect of air temperature	1 ppm/K										
Temperature drift	typ. 0.1 mm/K										
Measurement value output	2 ms										
Initialisation period	500 ms										
Max. running speed	10 m/s										
EMV	EN 61000-6-2, EN 55011: class B										
Mechanical load	Shock: EN 600 68-2-27/-2-29										
	Sine: EN 600 68-2-6										
	Noise: EN 600 68-2-64										

¹⁾ On reflective tape "Diamond Grade"
²⁾ Statistical error 1 σ , environmental conditions constant, minimal warm-up time: 10 min.

³⁾ Average service life 50,000 h at $T_A = +25$ °C
⁴⁾ Limit values

⁵⁾ May not exceed or fall short of V_S tolerances
⁶⁾ not reverse-polarity protected

⁷⁾ Max. 100 nF/20 mH
⁸⁾ Reference voltage 32 V DC

Order information	
Type	Part no.
DME5000-211	1 024 081
DME5000-212	1 024 082
DME5000-213	1 025 050
DME5000-214	1 025 834
DME5000-215	1 025 835
DME5000-221	1 024 085
DME5000-222	1 024 086
DME5000-223	1 025 251
DME5000-224	1 025 837

Measurement range
0.15 ... 300 m

Distance measuring device

- Short positioning processes: very fast measuring time
- High degree of system availability: highest accuracy and reproducibility
- Convenient operation startup: illuminated LCD display with diagnosis information
- Easy assembly and alignment concept: alignment bracket with spring/visible red light



Dimensional drawing

All types

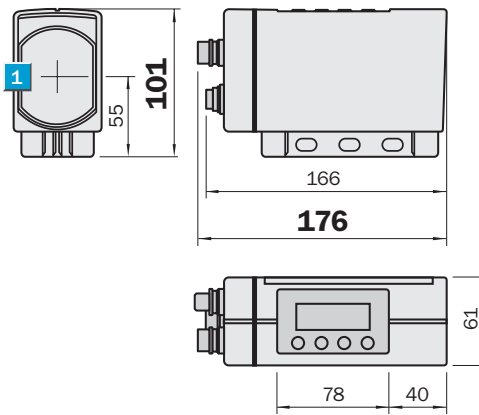

Back sight

DME5000-311	DME5000-312	DME5000-314	DME5000-315
DME5000-313			

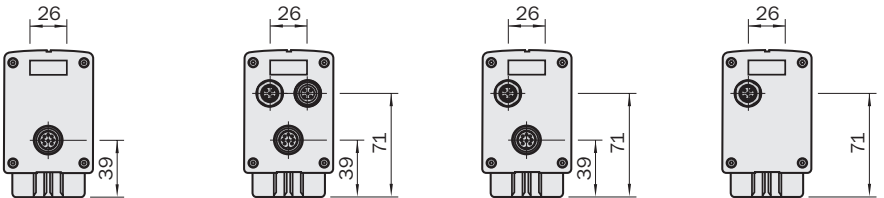

Adjustments possible

All types

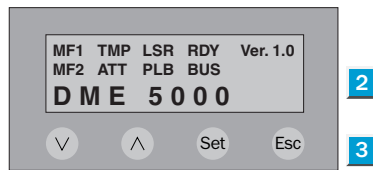

- 1 Centre of optical axis
- 2 LC display
- 3 Entry range

Connection type

DME5000-311	DME5000-312	DME5000-314	DME5000-315
DME5000-313			

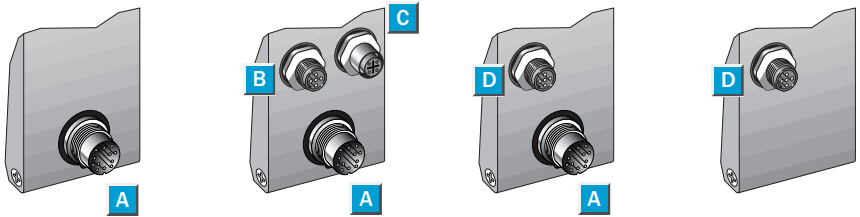

Connections

8-pin, M16	5-pin, M12 Bus in	5-pin, M12 Bus out	5-pin, M12 Bus in
------------	----------------------	-----------------------	----------------------

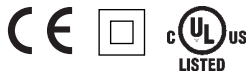
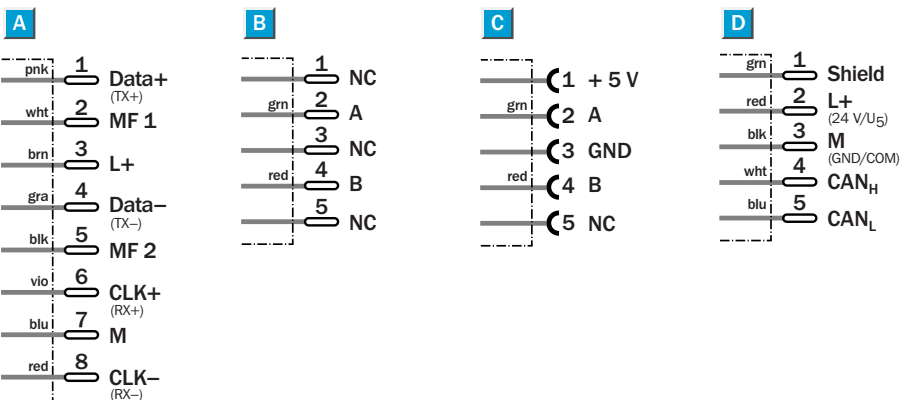

Accessories

- Connectors
- Mounting systems

Technical Data		DME5000-	311	312	313	314	315	321	322	323	324
Measurement range ¹⁾	0.15 ... 300 m										
Accuracy	±5 mm										
Reproducibility ²⁾	2 mm										
Light spot diameter	max. 550 mm at 300 m										
Resolution (adjustable)	0.05 ... 5 mm										
Light source ³⁾ , light type	Laser diode, red light										
Laser category	2 (IEC 60825-1/C.D.R.H.)										
Supply voltage V_S ⁴⁾	18 ... 30 V DC										
Residual ripple ⁵⁾	5 V _{pp}										
Current consumption	< 250 mA at 24 V DC										
	with heating < 1000 mA										
Switching outputs MF1, MF2	B (push/pull)										
Output (MF1/MF2)	HIGH: $U_V < 3$ V; LOW < 2 V										
Input (MF1) ⁶⁾	HIGH: > 12 V; LOW < 3 V										
Output current I_A max. ⁷⁾	100 mA (short-circuit/overload protected)										
Connection type	Plug										
VDE protection class ⁸⁾	□										
Enclosure rating	IP 65										
Ambient temperature	Operation -10 °C ... +55 °C										
	with heating Operation -40 °C ... +55 °C										
	Storage -25 °C ... +75 °C										
Weight	approx. 1650 g										
Interfaces	SSI										
	Profibus 12 MBd										
	RS 422										
	DeviceNet 500 KBd										
Effect of air pressure	0.3 ppm/hPa										
Effect of air temperature	1 ppm/K										
Temperature drift	typ. 0.1 mm/K										
Measurement value output	2 ms										
Initialisation period	800 ms										
Max. running speed	5 m/s										
EMV	EN 61000-6-2, EN 55011: class B										
Mechanical load	Shock: EN 600 68-2-27/-2-29										
	Sine: EN 600 68-2-6										
	Noise: EN 600 68-2-64										

¹⁾ On reflective tape "Diamond Grade"
²⁾ Statistical error 1 σ , environmental conditions constant, minimal warm-up time: 10 min.

³⁾ Average service life 50,000 h at $T_A = +25$ °C
⁴⁾ Limit values

⁵⁾ May not exceed or fall short of V_S tolerances
⁶⁾ not reverse-polarity protected

⁷⁾ Max. 100 nF/20 mH
⁸⁾ Reference voltage 32 V DC

Order information	
Type	Part no.
DME5000-311	1 025 244
DME5000-312	1 025 245
DME5000-313	1 025 252
DME5000-314	1 026 002
DME5000-315	1 026 003
DME5000-321	1 025 246
DME5000-322	1 025 247
DME5000-323	1 025 253
DME5000-324	1 026 004

Dimensional drawings and order information

Connectors for Profibus, SSI and RS-422 interface

Female connector M16, 8-pin, straight

Type	Part. no
DOS-1608-GA	6 025 726

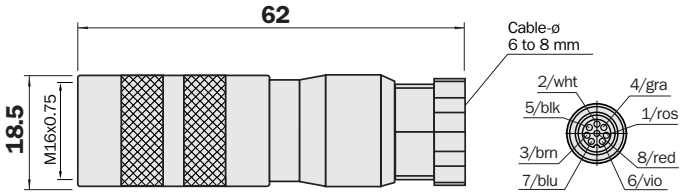

Female connector M16, 8-pin, right angle

Type	Part. no
DOS-1608-WA	6 025 727

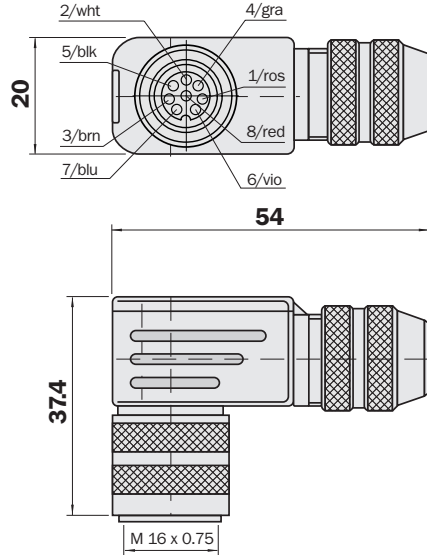

Female connector M16, 8-pin, straight

Type	Part. no	Cable length
DOL-1608-G05MA	2 026 742	5 m
DOL-1608-G10MA	2 027 193	10 m

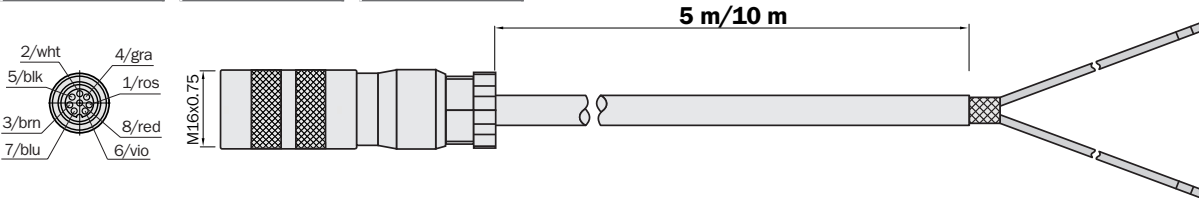

Female connector M16, 8-pin, right angle

Type	Part. no	Cable length
DOL-1608-W05MA	2 026 743	5 m
DOL-1608-W10MA	2 027 194	10 m

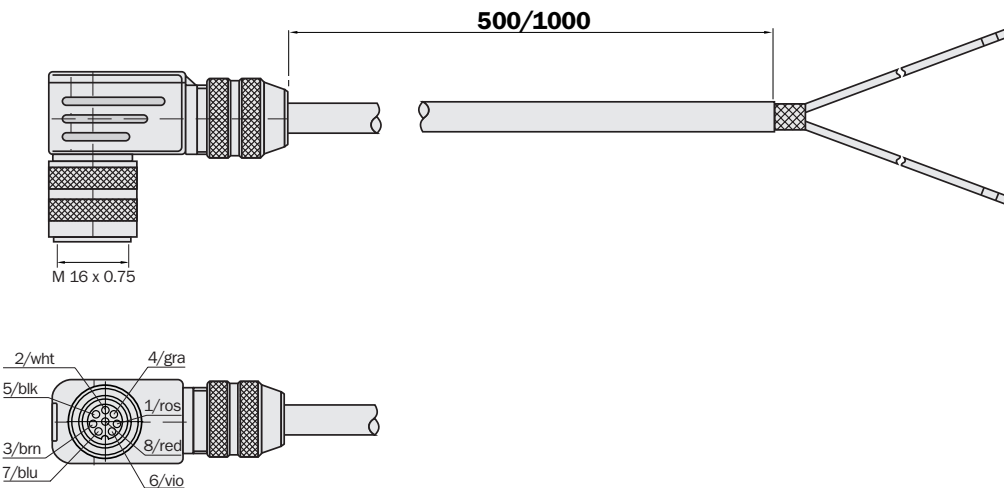

Dimensional drawings and order information

Cable 2 x 0.5 mm², 6 x 0.25 mm², twisted 2 x in pairs, shielded

Type	Part. no
LTG-2308-MW	6 026 292

Technical data	
Temperature range	variabel -5 ... +70 °C not variabel -40 ... +80 °C
Sheath	PUR grey
Shield	tined copper net

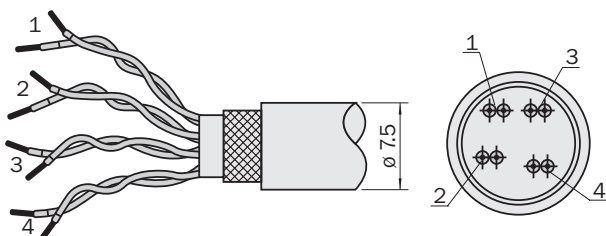

Connectors for Profibus interface

Profibus terminal resistor

Type	Part. no
PR-STE-END	6 021 156

Profibus female connector M12, 5-pin, Bus in

Type	Part. no
PR-DOS-1205-G	6 021 353

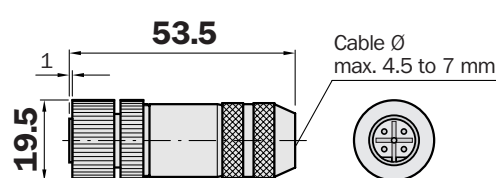
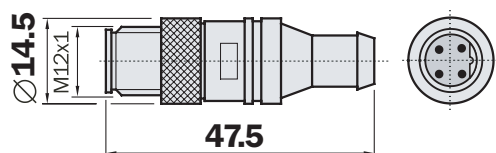

Profibus male connector M12, 5-pin, Bus out

Type	Part. no
PR-STE-1205-G	6 021 354

Profibus cable, 2 x 0.34 mm², by the metre

Type	Part. no
LTG-2102-MW	6 021 355

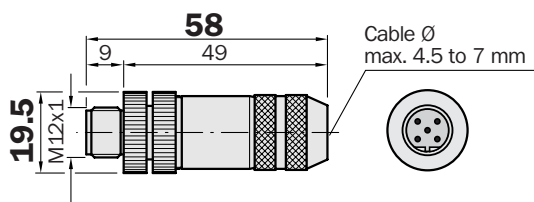

Technical data	
Temperature range	variabel -5 ... +80 °C not variabel -40 ... +80 °C
Sheath	PUR violett Ø 8 mm
Shield	AL-PT tape

Female connector with Profibus cable, Bus in

Type	Part. no	Cable length
DOL-12PR-G05	6 026 006	5 m
DOL-12PR-G10	6 026 007	10 m

Male connector with Profibus cable, Bus out

Type	Part. no	Cable length
STL-12PR-G05	6 026 005	5 m
STL-12PR-G10	6 026 008	10 m

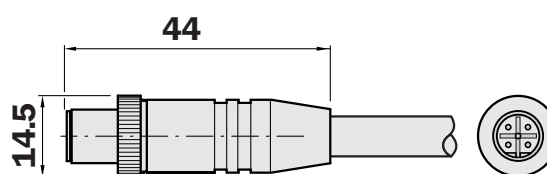
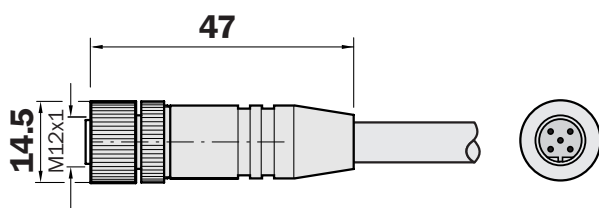

Dimensional drawings and order information

Connectors for DeviceNet interface

Female connector M12, 5-pin, straight, shielded
360°-Shielding on rim nut, sizeable

Type	Part. no
DOS-1205-GA	6 027 534

Male connector M12, 5-pin, straight, shielded
360°-Shielding on rim nut, sizeable

Type	Part. no
STE-1205-GA	6 027 533

DeviceNet female connector M12, 5-pin, straight
Cable 6 m, Dropcable

Type	Part. no
DOL-1205-G06MK	6 028 326

DeviceNet extension cable 6 m, female connector M12, 5-pin, straight
Plug M12, 5-pin, straight, Dropcable

Type	Part. no
DSL-1205-G06MK	6 028 327

DeviceNet-T-piece female connector M12, 5-pin, on male connector,
female connector 7/8", 5-pin

Type	Part. no
SD0-02D78-SF	6 028 330

DeviceNet terminal resistor, female connector 7/8", 5-pin, straight

Type	Part. no
DOS-7805-GKEND	6 028 329

DeviceNet female connector 7/8", 5-pin, straight, PG16, sizeable

Type	Part. no
DOS-7805-GK	6 028 331

DeviceNet male connector 7/8", 5-pin, straight, PG16, sizeable

Type	Part. no
STE-7805-GK	6 028 332

Cable, 4 x 0,34 mm², twisted 2 x in pairs, shielded with AL-PT tape

Type	Part. no	Technical data	
LTG-2804-MW	6 028 328	Temperature range	variabel -10 ... +70 °C not variabel -40 ... +70 °C
		Sheath	PUR black Ø 6,8 mm
		Shield	Cu tined

Dimensional drawings and order information

Reflectors

Reflector, 0.3 x 0.3 m², "Diamond Grade", mounted

Type	Part. no
PL 240 DG	1 017 910

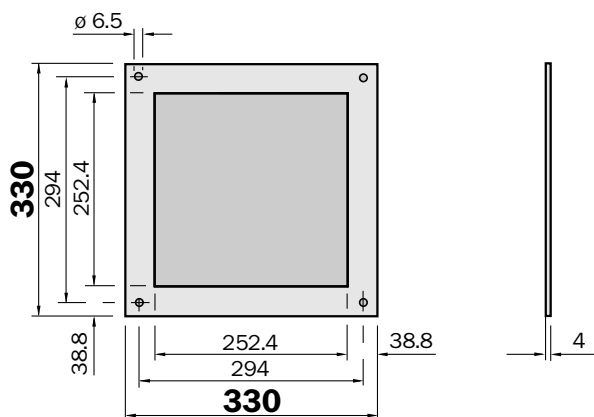

Reflector, 0.6 x 0.6 m², "Diamond Grade", mounted

Type	Part. no
PL 560 DG	1 016 806

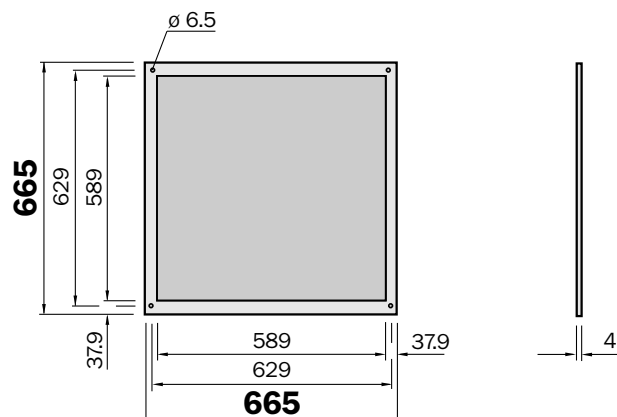

Reflector, 1 x 1 m², "Diamond Grade", mounted

Type	Part. no
PL 880 DG	1 018 975

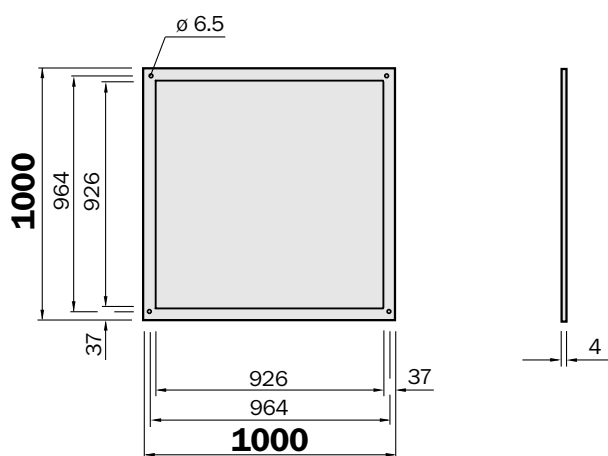

Reflector, 0.3 x 0.3 m², "Diamond Grade" regulated heating 230 V AC/200 W

Type	Part. no
PL 240 DG-H	1 022 926

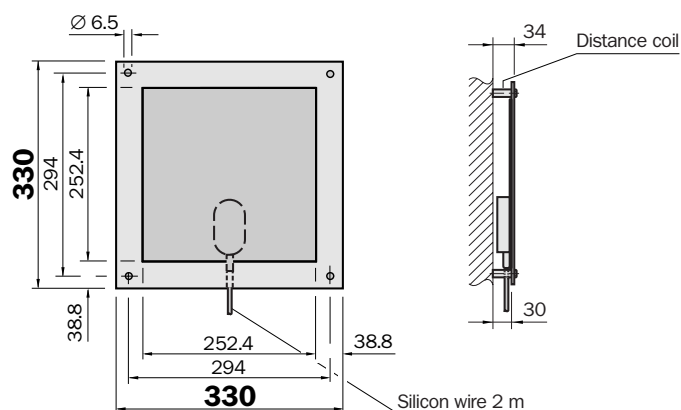

Reflector, 0.6 x 0.6 m², "Diamond Grade" regulated heating 230 V AC/900 W

Type	Part. no
PL 560 DG-H	1 023 888

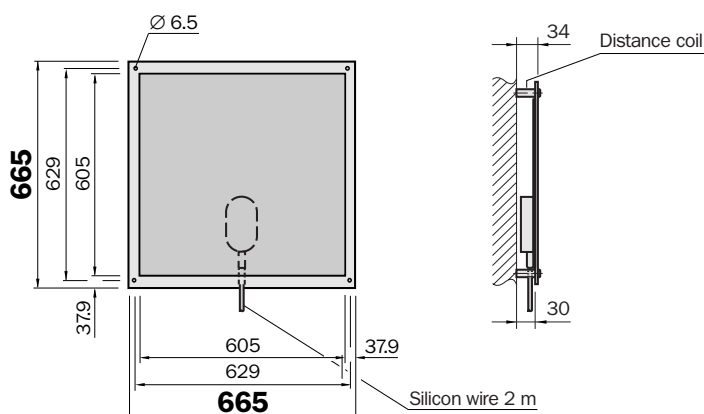

Reflective tape "Diamond Grade"

Type	Part. no	
REF-DK-K	4 019 634	Cut to size
REF-DG	5 304 334	Sheet 749 x 914 mm ²



Dimensional drawings and order information

Alignment bracket

Type	Part. no
BEF-AH-DME5	2 027 721

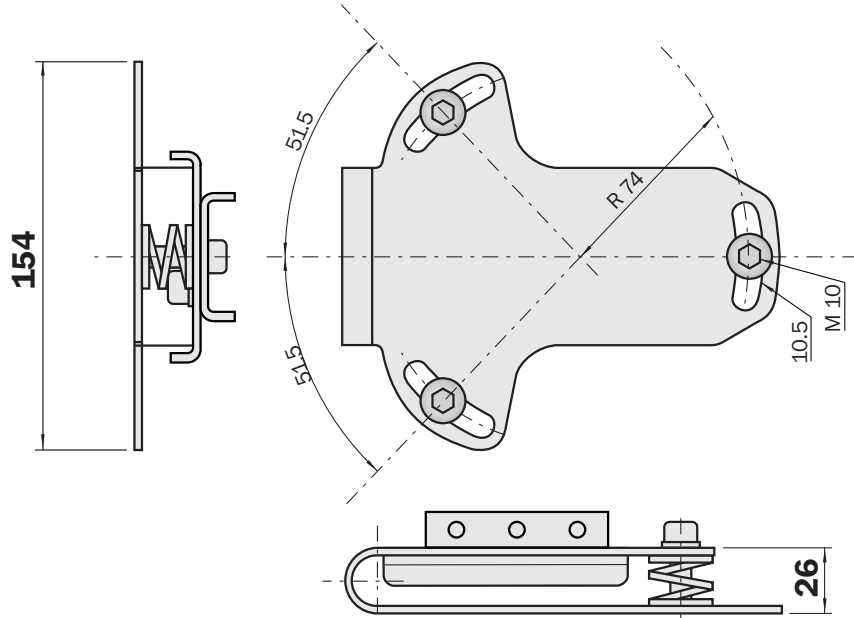

Weather-protecting hood

Type	Part. no
WSG-DME5	2 027 800

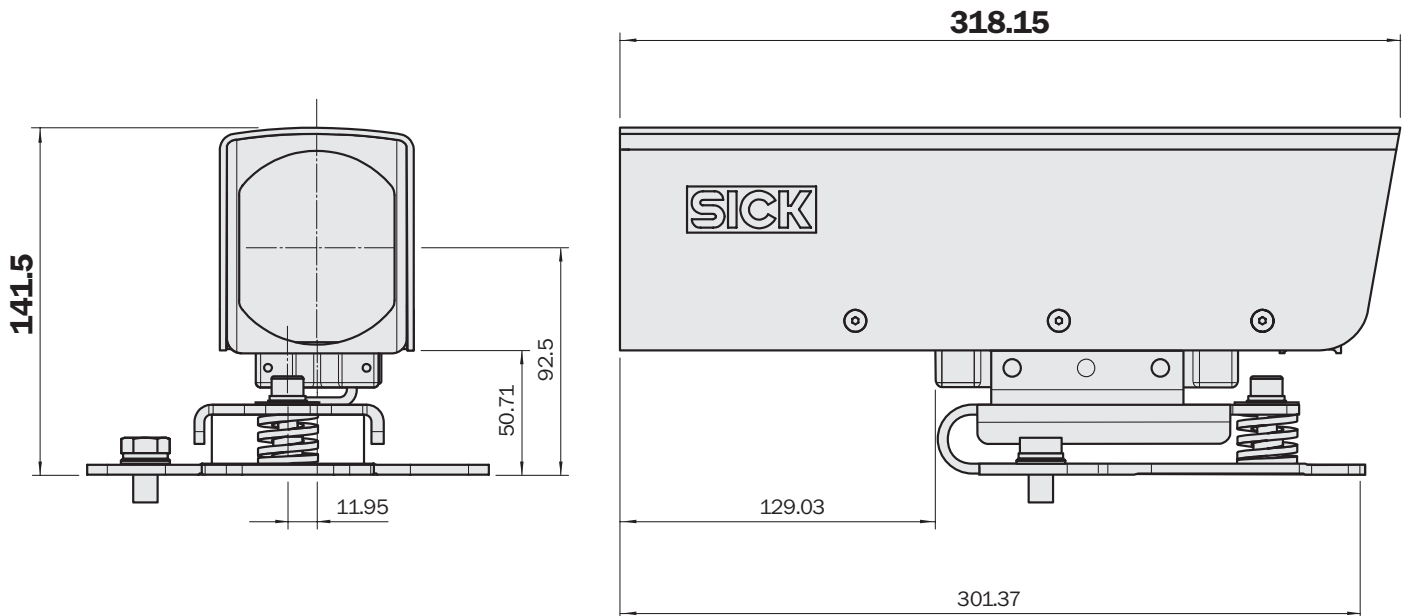

Dimensional drawings and order information

Corner mirror, deflection of light emission upward

Type	Part. no
USP-DME5	2 027 710

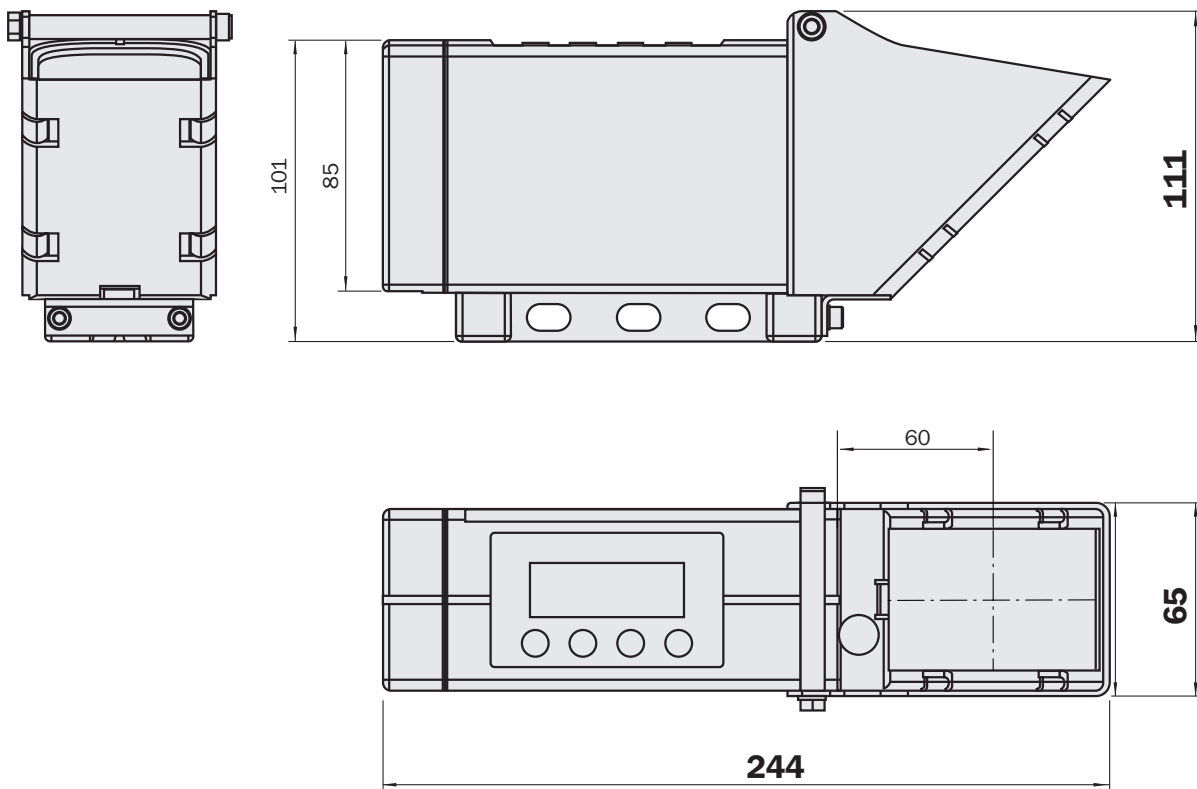

Your contacts:

Australia

Phone +61 3 94 97 41 00
1800 33 48 02 – toll free
Fax +61 3 94 97 11 87

Austria

Phone +43 2 23 66 22 88-0
Fax +43 2 23 66 22 88-5

Belgium/Luxembourg

Phone +32 24 66 55 66
Fax +32 24 63 31 04

Brazil

Phone +55 11 50 91 49 00
Fax +55 11 55 35 41 53

China

Phone +8 52 27 63 69 66
Fax +8 52 27 63 63 11

Czech Republik

Phone +42 02 579 11 850
Fax +42 02 578 10 559

Denmark

Phone +45 45 82 64 00
Fax +45 45 82 64 01

Finland

Phone +3 58-9-25 15 800
Fax +3 58-9-25 15 8055

France

Phone +33 1 64 62 35 00
Fax +33 1 64 62 35 77

Germany

Phone +49 2 11 53 01 0
Fax +49 2 11 53 01 100

Great Britain

Phone +44 17 27-83 11 21
Fax +44 17 27-85 67 67

Italy

Phone +39 02 27 40 93 19
Fax +39 02 27 40 90 87

Japan

Phone +8 13 33 58 13 41
Fax +8 13 33 58 90 48

Korea

Phone +82 2 786 63 21/4
Fax +82 2 786 63 25

Netherlands

Phone +31 30 229 25 44
Fax +31 30 229 39 94

Norway

Phone +47 67 81 50 00
Fax +47 67 81 50 01

Poland

Phone +48 22 8 37 40 50
Fax +48 22 8 37 43 88

Singapore

Phone +65 67 44 37 32
Fax +65 68 41 77 47

Spain

Phone +34 93 4 80 31 00
Fax +34 93 4 73 44 69

Sweden

Phone +46 8 6 80 64 50
Fax +46 8 7 10 18 75

Switzerland

Phone +41 4 16 19 29 39
Fax +41 4 16 19 29 21

Taiwan

Phone +88 62 23 65 62 92
Fax +88 62 23 68 73 97

USA/Canada/Mexico

Phone +1(952) 9 41-67 80
Fax +1(952) 9 41-92 87

Representatives and agencies
in all major industrial nations.

SICK